



ROKU-ROKU

SINCE 1903

MEGA SSS-400/600 5AXP

Super Hybrid Concept

Small Hole Drilling

Micro Fine 5-Axis Milling

Highly Rigid Structure

- High rigidity, bridge-type monoblock structure allows high-speed, high-precision machining surpassing typical "C-Frame" construction by far.
- Minimized distance between guide surface and spindle center provides greater stability.
- High rigidity bed with ideal rib distribution has been designed by computer analysis.
- With linear scales included as standard equipment, Roku-Roku guarantees static positioning accuracy $\pm 0.000040"$ and $\pm 0.000012"$ repeatability.

Extended Speed Range

- Capable of a wide range (3,000 through 40,000 RPM) standard and up to 60,000 RPM optional, using a long-life integral AC motor. Ideal for micro drilling and milling applications.

Z-axis Balance Cylinder

- Single Balance Cylinder, standard equipment on MEGA SSS-400 / 600, reduces load for the ball screw and servo motor allowing smooth motion of the Z-axis.

Fanuc 31i-B5 Super High-Speed Processor & AI Contour Control II

- The Fanuc 31i-B5 is a "NANO CNC System" with Intelligent Velocity Control, NANO Interpolation and NANO Smoothing. The look ahead has been expanded to 1000 blocks. The full 5-Axis Machining Package has been added for simultaneous 5-axis operation.

Multiple Applications

- High-speed direct 5-axis hard milling can be done by dry machining.
- Flush system is ideal for soft material 5-axis machining and micro drilling.
- Mega-precision capability is ideal for non-metallic machining ie, Soda Glass, Zirconia and Machinable Ceramics.



The Ultimate Machine for Small Hole Drilling and Micro Fine 5-Axis Milling

Now Available

From MC Machinery Systems, Inc.

MC MACHINERY SYSTEMS, INC.

a subsidiary of Mitsubishi Corporation

ROKU-ROKU

SINCE 1903

SPECIFICATIONS

MEGA SSS-400/600 5AXP	
X x Y x Z Travels (in.)	16.1 x 13.0 x 7.9
Table Work Area (in.)	23.6 x 13.0
Max. Load on Table (lb.)	220
Rotary Faceplate to Spindle Nose (in.)	8.94
Max. Workpiece Weight Rotary (lb.)	44
Rotary Table Faceplate Dia. (in.)	3.94
Max. A-Axis Tilt Angle (deg.)	-120 ~ +10
Max. A-Axis Rotation Speed	12.5 RPM
Max. C-Axis Rotation Speed	22 RPM
Max. Part Dia. on Faceplate (.67" above)	6.14 (7.87)
Linear Scales X, Y, Z-axes	Heidenhain 0.00002mm Standard
Positioning Accuracy Full Stroke	±0.000039 (±1.0µm)
Repeatability	±0.000012 (±0.3µm)
Actual Measured Circularity (2.0" dia. at 8 IPM)	0.000039" (1.0µm)
Spindle Speed	3,000~40,000 (60,000 RPM w Opt.)
Spindle Taper	HSK-E25
Spindle Air Purge	Standard
ATC (Automatic Tool Changer)	20 Position Standard (40 or 60 w option)
Rapid Traverse Speed	590"/min.
Cutting Speed (Normal Mode)	0.01 ~ 394"/min.
Cutting Speed (GR Super PC Mode)	590"/min.
Machine Weight (lb.)	6173
Machine Height (in.)	90.1
Required Floor Space w Options W x D	79.1" x 106"
Control Unit	Fanuc 31i-B5 with 5-axis package
Power Required	200~220VAC 16.5 kVA w options
Air Supply	9 cu.ft./min. @ 72 psi

High Aspect Ratio Drilling

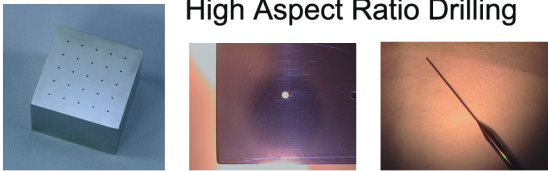

Material: SS - Hole Dia: 0.5mm - Depth: 25mm

Tungsten Carbide Machining

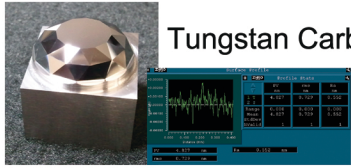

HAND CRAFTED TO JIG-BORER STANDARDS

Roku-Roku's vertical machining centers are hand crafted and built solidly to jig-borer standards. The company still hand scrapes mating surfaces to eliminate vibration and by using Fine Element Design (FEA), creates it's machine bases with three point leveling system for maximum rigidity. Roku-Roku VMCs combine state-of-the-art spindle technology, smooth-action roller pack type linear guides and the latest in high speed Fanuc control with linear glass scales. The result? A smoother finish and higher accuracy parts than other VMCs can produce.

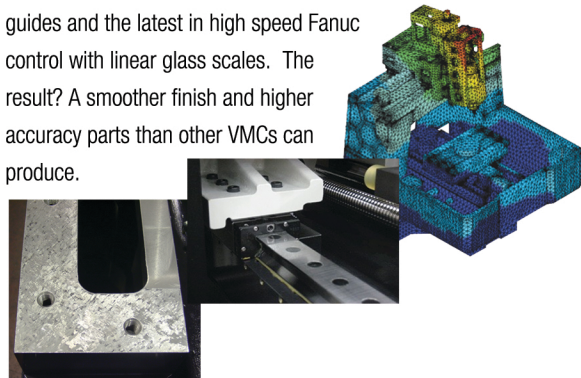

Roku-Roku MEGA SSS-400/600 5AXP Precision 5-Axis Machining Center

Unit: mm (inch)

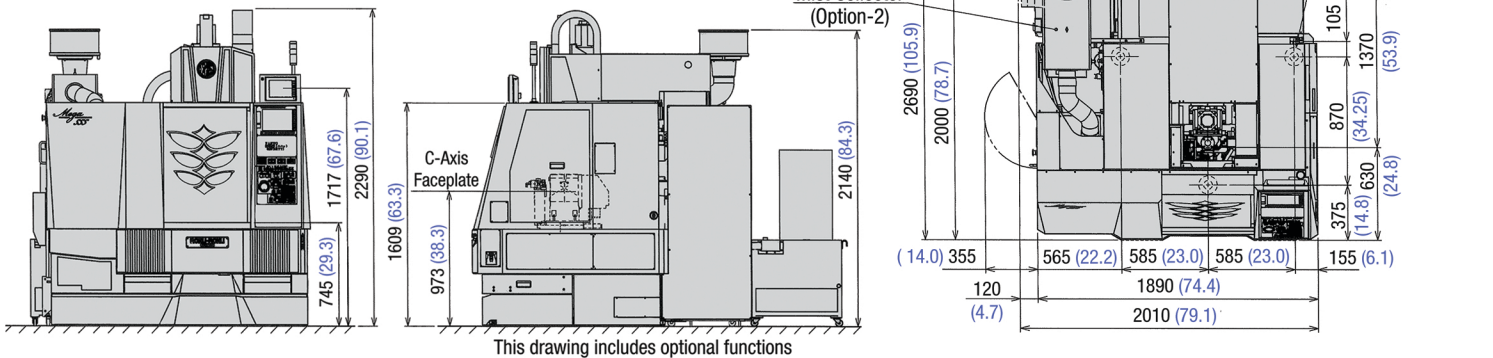

Machine Height: 90.1" Installation Footprint: 79.1" x 106.0" Machine Weight: 6,173lbs.
 Power Requirement: 208V +/-10%, 60Hz, 16.5kVA Compressed Air Supply: 9.0cu.ft./min. @ 72psi.

MC MACHINERY SYSTEMS, INC.
 a subsidiary of Mitsubishi Corporation