

CHANGES		DATE
SYL	BY	REVISION

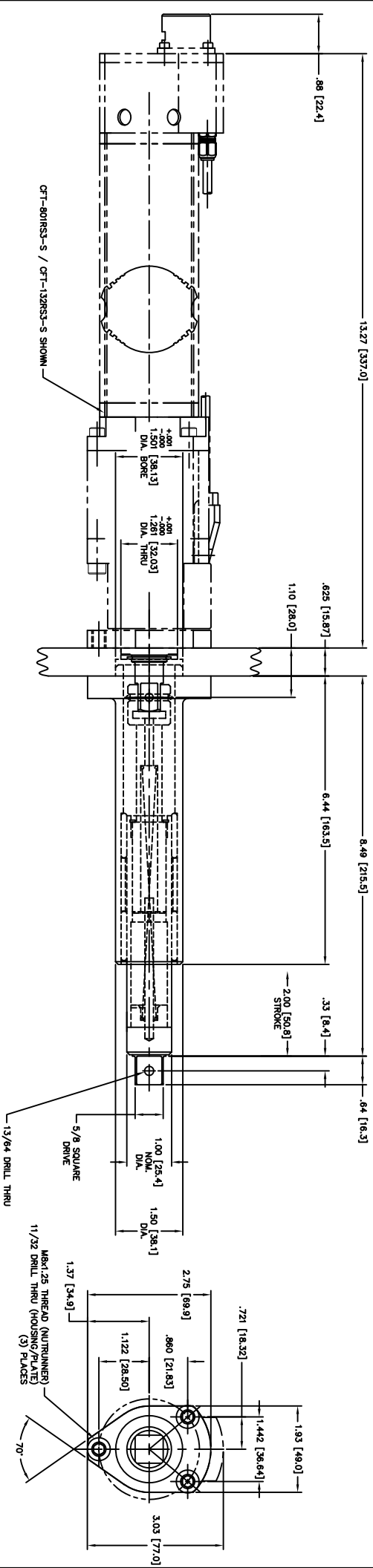

SPINDLE ASSEMBLY WEIGHT (SPDL ASSY ONLY) - 35LB

TOLERANCE UNLESS OTHERWISE SPECIFIED
 INCH METRIC
 .XX ±.01 .XX ±.25
 .XXX ±.005 .XXX ±.127
 .XXXX ±.0005 .XXXX ±.0127
 ANGLE ±.5° ANGLE ±.5°
 BREAK ALL SHARP CORNERS &
 EDGES EXCEPT AS NOTED
 DO NOT SCALE DRAWING

NOTICE OF PROPRIETARY RIGHTS
 This drawing is the property of MCG Machinery Systems, Inc. and use is to be restricted in each condition, no element of this drawing is to be reproduced, stored in a retrieval system, or transmitted in any form or by any means, electronic, mechanical, photocopying, recording, or by any information storage and retrieval system, without the express written permission of MCG Machinery Systems, Inc.

MCG MACHINERY SYSTEMS, INC.
 a subsidiary of **Mitsubishi Corporation**
 1400 W. 14th Street, Suite 100, Minneapolis, MN 55404
 Phone: (612) 895-4210 Fax: (612) 895-1872
 Website: www.mcg-machinery.com

DESIGNER: [Name] TITLE: STRAIGHT SPINDLE ADAPTOR
 DRAFTER: [Name] TITLE: STRAIGHT SPINDLE ADAPTOR
 CHECKED BY: [Name] TITLE: STRAIGHT SPINDLE ADAPTOR
 DATE: [Date]
 SCALE: [Scale]
 SHEET: [Number] OF [Total]
 DRAWING NO. SA-353-2-50-62